

ENGLISH

Prerequisite Charts for English, Grades 9–12

These charts map out all the courses in the discipline and show the links between courses and the possible prerequisites for them. They do not attempt to depict all possible movements from course to course.

Compulsory Courses

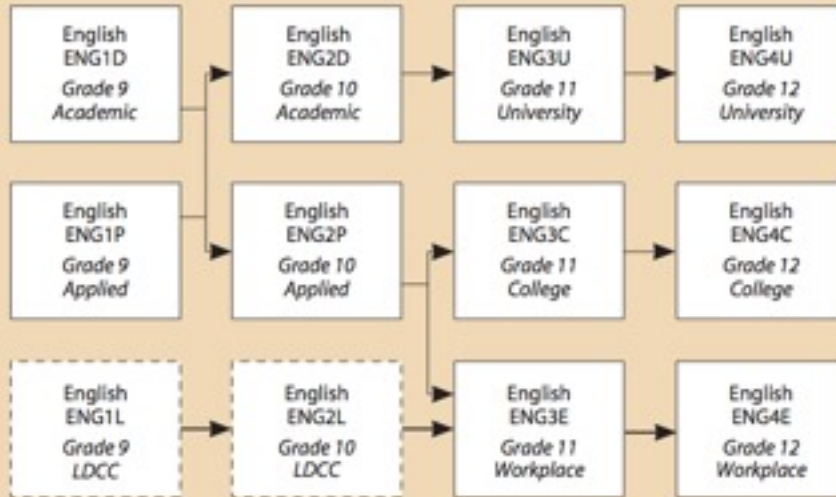

COMPULSORY ENGLISH COURSE DESCRIPTIONS

English, Grade 9, Academic

ENG 1D

This course is designed to develop the oral communication, reading, writing, and media literacy skills that students need for success in their secondary school academic programs and in their daily lives. Students will analyse literary texts from contemporary and historical periods, interpret informational and graphic texts, and create oral, written, and media texts in a variety of forms. An important focus will be on the use of strategies that contribute to effective communication. The course is intended to prepare students for the Grade 10 academic English course, which leads to university or college preparation courses in Grades 11 and 12.

Prerequisite: None

English, Grade 9, Applied

ENG 1P

This course is designed to develop the key oral communication, reading, writing, and media literacy skills students need for success in secondary school and daily life. Students will read, interpret, and create a variety of informational, literary, and graphic texts. An important focus will be on identifying and using appropriate strategies and processes to improve students' comprehension of texts and to help them communicate clearly and effectively. The course is intended to prepare students for the Grade 10 applied English course, which leads to college or workplace preparation courses in Grades 11 and 12.

Prerequisite: None

English, Grade 10, Academic

ENG 2D

This course is designed to extend the range of oral communication, reading, writing, and media literacy skills that students need for success in their secondary school academic programs and in their daily lives. Students will analyse literary texts from contemporary and historical periods, interpret and evaluate informational and graphic texts, and create oral, written, and media texts in a variety of forms. An important focus will be on the selective use of strategies that contribute to effective communication. This course is intended to prepare students for the compulsory Grade 11 university or college preparation course.

Prerequisite: English, Grade 9, Academic or Applied

English, Grade 10, Applied

ENG 2P

This course is designed to extend the range of oral communication, reading, writing, and media literacy skills that students need for success in secondary school and daily life. Students will study and create a variety of informational, literary, and graphic texts. An important focus will be on the consolidation of strategies and processes that help students interpret texts and communicate clearly and effectively. This course is intended to prepare students for the compulsory Grade 11 college or workplace preparation course.

Prerequisite: English, Grade 9, Academic or Applied

English, Grade 11, University Preparation

ENG 3U

This course emphasizes the development of literacy, communication, and critical and creative thinking skills necessary for success in academic and daily life. Students will analyse challenging literary texts from various periods, countries, and cultures, as well as a range of informational and graphic texts, and create oral, written, and media texts in a variety of forms. An important focus will be on using language with precision and clarity and incorporating stylistic devices appropriately and effectively. The course is intended to prepare students for the compulsory Grade 12 university or college preparation course.

Prerequisite: English, Grade 10, Academic

English, Grade 11, College Preparation

ENG 3C

This course emphasizes the development of literacy, communication, and critical and creative thinking skills necessary for success in academic and daily life. Students will study the content, form, and style of a variety of informational and graphic texts, as well as literary texts from Canada and other countries, and create oral, written, and media texts in a variety of forms for practical and academic purposes. An important focus will be on using language with precision and clarity. The course is intended to prepare students for the compulsory Grade 12 college preparation course.

Prerequisite: English, Grade 10, Applied

English, Grade 11, Workplace Preparation

ENG 3E

This course emphasizes the development of literacy, communication, and critical and creative thinking skills necessary for success in the workplace and in daily life. Students will study the content, form, and style of a variety of contemporary informational, graphic, and literary texts; and create oral, written, and media texts in a variety of forms for practical purposes. An important focus will be on using language clearly and accurately in a variety of formal and informal contexts. The course is intended to prepare students for the compulsory Grade 12 workplace preparation course.

Prerequisite: English, Grade 10, Applied

English, Grade 12, University Preparation

ENG 4U

This course emphasizes the consolidation of the literacy, communication, and critical and creative thinking skills necessary for success in academic and daily life. Students will analyse a range of challenging literary texts from various periods, countries, and cultures; interpret and evaluate informational and graphic texts; and create oral, written, and media texts in a variety of forms. An important focus will be on using academic language coherently and confidently, selecting the reading strategies best suited to particular texts and particular purposes for reading, and developing greater control in writing. The course is intended to prepare students for university, college, or the workplace.

Prerequisite: English, Grade 11, University Preparation

English, Grade 12, College Preparation

ENG 4C

This course emphasizes the consolidation of literacy, communication, and critical and creative thinking skills necessary for success in academic and daily life. Students will analyse a variety of informational and graphic texts, as well as literary texts from various countries and cultures, and create oral, written, and media texts in a variety of forms for practical and academic purposes. An important focus will be on using language with precision and clarity and developing greater control in writing. The course is intended to prepare students for college or the workplace.

Prerequisite: English, Grade 11, College Preparation

English, Grade 12, Workplace Preparation

ENG 4E

This course emphasizes the consolidation of literacy, communication, and critical and creative thinking skills necessary for success in the workplace and in daily life. Students will analyse informational, graphic, and literary texts and create oral, written, and media texts in a variety of forms for workplace-related and practical purposes. An important focus will be on using language accurately and organizing ideas and information coherently. The course is intended to prepare students for the workplace and active citizenship.

Prerequisite: English, Grade 11, Workplace Preparation

OPTIONAL ENGLISH COURSE DESCRIPTIONS.

THESE COURSES DO NOT COUNT AS ONE OF THE 4 COMPULSORY ENGLISH CREDITS, BUT ARE FOR INTEREST, AND ELECTIVE CREDITS.

Media Studies, Grade 11, Open

EMS 30

This course emphasizes knowledge and skills that will enable students to understand media communication in the twenty-first century and to use media effectively and responsibly. Through analysing the forms and messages of a variety of media works and audience responses to them, and through creating their own media works, students will develop critical thinking skills, aesthetic and ethical judgement, and skills in viewing, representing, listening, speaking, reading, and writing.

Prerequisite: English, Grade 10, Academic or Applied

The Writer's Craft, Grade 12, University Preparation

EWC 4U

This course emphasizes knowledge and skills related to the craft of writing. Students will analyse models of effective writing; use a workshop approach to produce a range of works; identify and use techniques required for specialized forms of writing; and identify effective ways to improve the quality of their writing. They will also complete a major paper as part of a creative or analytical independent study project and investigate opportunities for publication and for writing careers.

Prerequisite: English, Grade 11, University Preparation